

HIGH RELIABILITY DC-DC CONVERTER

230-400 V Continuous Input	155-450 V Transient Input	28 V Output	400 W Output	95%@7 A / 95%@14 A Efficiency
--------------------------------------	-------------------------------------	-----------------------	------------------------	---

OPERATION: -55°C TO +125°C

The MilQor® series of high-reliability DC-DC converters brings SynQor's field proven high-efficiency synchronous rectifier technology to the Military/Aerospace industry. SynQor's innovative QorSeal® packaging approach ensures survivability in the most hostile environments. Compatible with the industry standard format, these converters operate at a fixed frequency, have no opto-isolators, and follow conservative component derating guidelines. They are designed and manufactured to comply with a wide range of military standards.

MilQor®

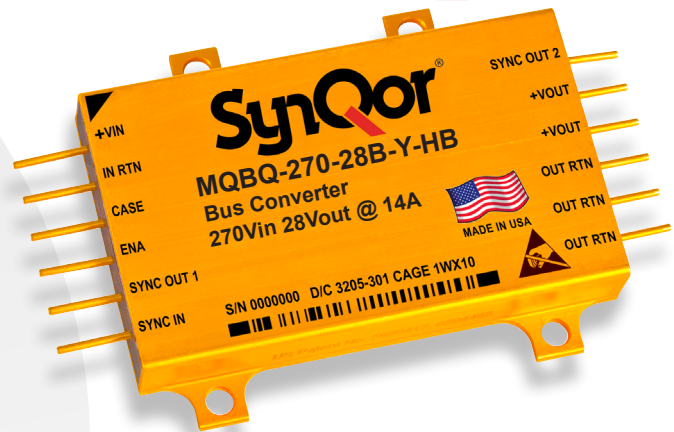

DESIGNED & MANUFACTURED IN THE USA
FEATURING QORSEAL® HI-REL ASSEMBLY

Design Process

MQBQ series converters are:

- Designed for reliability per NAVSO-P3641-A guidelines
- Designed with components derated per:
 - MIL-HDBK-1547A
 - NAVSO P-3641A

Qualification Process

MQBQ series converters are qualified to:

- MIL-STD-810F
 - consistent with RTCA/DO-160E
- SynQor's First Article Qualification
 - consistent with MIL-STD-883F
- SynQor's Long-Term Storage Survivability Qualification
- SynQor's on-going life test

In-Line Manufacturing Process

- AS9100 and ISO 9001 certified facility
- Full component traceability
- Temperature cycling
- Constant acceleration
- 24, 96, 160 hour burn-in
- Three level temperature screening

Features

- Fixed switching frequency
- No opto-isolators
- Parallel operation with droop current share
- Clock synchronization
- Continuous short circuit and overload protection
- Input under-voltage and over-voltage shutdown

Specification Compliance

MQBQ series converters (with MQME filter) are designed to meet:

- MIL-HDBK-704-7 (A through F)
- RTCA/DO-160 Section 16, 17, 18
- MIL-STD-1275 (B, D)
- DEF-STAN 61-5 (part 6)/(5, 6)
- MIL-STD-461 (C, D, E, F)
- RTCA/DO-160(E, F, G) Section 22



Technical Specification

MQBQ-270-28B
Output: 28V
Current: 14A

BLOCK DIAGRAM

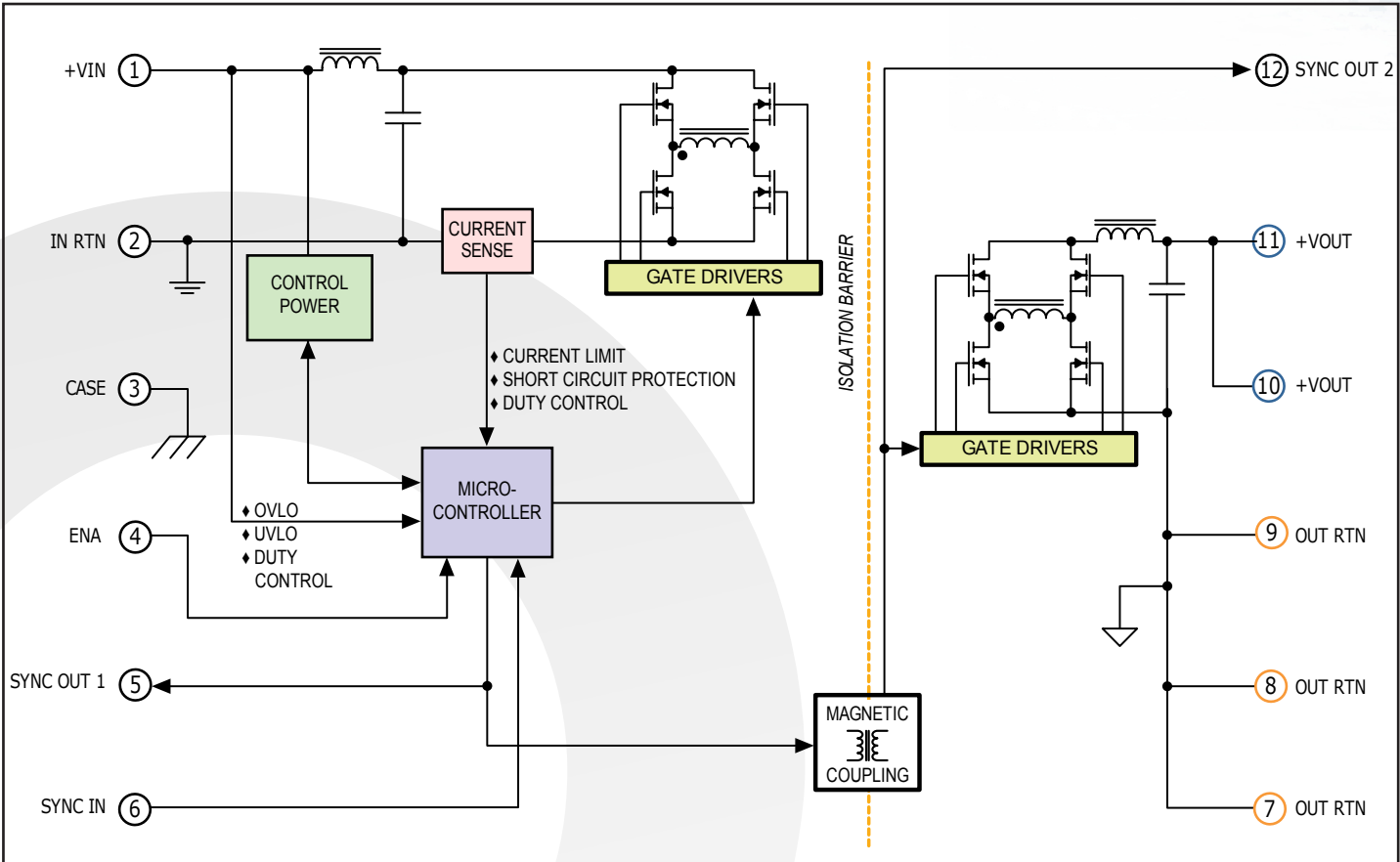

TYPICAL CONNECTION DIAGRAM

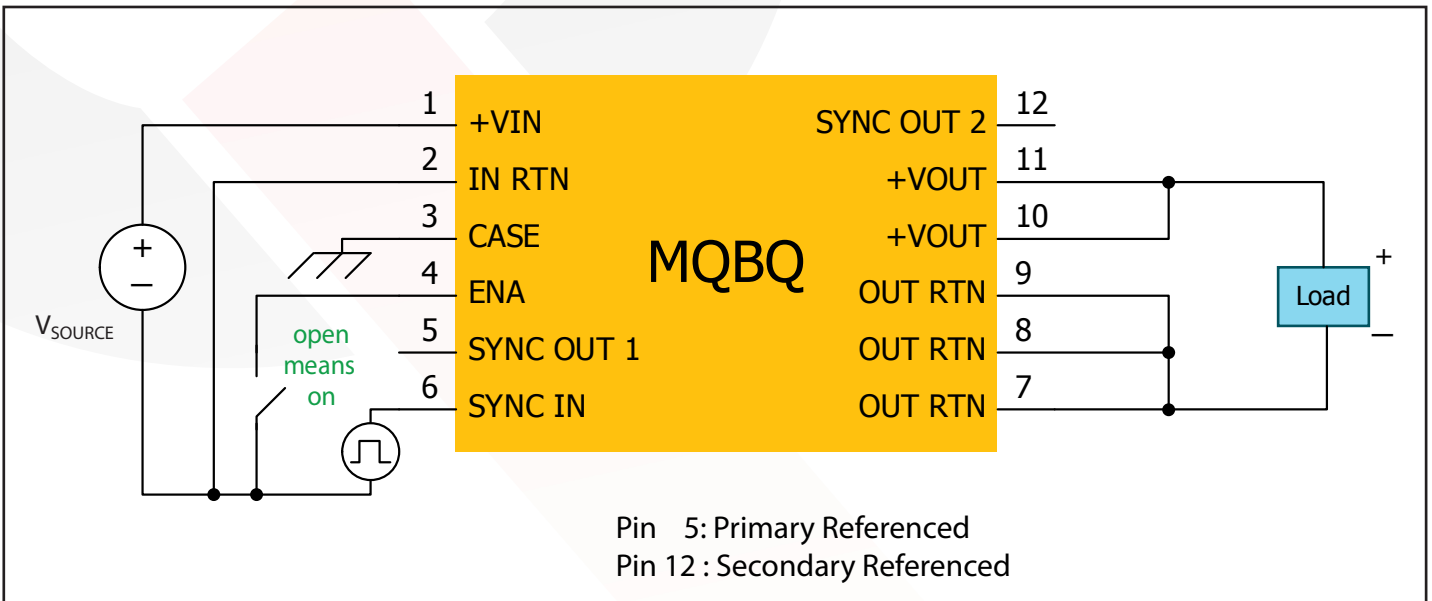

Technical Specification
MQBQ-270-28B ELECTRICAL CHARACTERISTICS

Parameter	Min.	Typ.	Max.	Units	Notes & Conditions	Group A Subgroup (see Note 8)
Specifications subject to change without notice						
ABSOLUTE MAXIMUM RATINGS						
Input Voltage						
Non-Operating			600	V		
Operating			550	V	See Note 1	
Reverse Bias (Tcase = 125 °C)			-0.8	V		
Reverse Bias (Tcase = -55 °C)			-1.2	V		
Isolation Voltage (I/O to case, I to O)						
Continuous	-500		500	V		
Transient (<=100 µs)	-800		800	V		
Operating Case Temperature	-55		125	°C	HB Grade Products, See Notes 2 & 10	
Storage Case Temperature	-65		135	°C		
Lead Temperature (20 s)			300	°C		
Voltage at ENA	-1.2		50	V		
INPUT CHARACTERISTICS						
Operating Input Voltage Range	230	270	400	V	Continuous	1, 2, 3
" "	155	270	450	V	Transient, 0.1 s	See Note 5
Input Under-Voltage Shutdown					See Note 3	
Turn-On Voltage Threshold	147	155	163	V		1, 2, 3
Turn-Off Voltage Threshold	142	150	157	V		1, 2, 3
Shutdown Voltage Hysteresis	1	5	10	V		See Note 5
Input Over-Voltage Shutdown					See Note 3	
Turn-Off Voltage Threshold > 0.1 s	408	422	447	V		See Note 5
Turn-Off Voltage Threshold	457	476	496	V		See Note 5
Turn-On Voltage Threshold	401	412	438	V		See Note 5
Shutdown Voltage Hysteresis	4	9	14	V		See Note 5
Maximum Input Current			2.5	A	Vin = 230 V; Iout = 16 A	See Note 5
No Load Input Current (operating)		28	40	mA	Vin = 230 V to 400 V	1, 2, 3
Disabled Input Current		1	4	mA	Vin = 230 V to 400 V	1, 2, 3
Input Terminal Current Ripple (pk-pk)		105	200	mA	Bandwidth = 100 kHz to 20 MHz; see Figure 14	See Note 5
OUTPUT CHARACTERISTICS						
Output Voltage Set Point (Tcase = 25 °C)	28.8	29.1	29.3	V	Vin = 270 V; Iout = 7 A	1
Input / Output Voltage Ratio		9		V/V	Transformer turns ratio	
Output Voltage Droop		0.041		Ω	Iout = 0 A to 14 A	
Output Voltage Variation		0.7	1.0	V	Vin = 270 V; Iout = 0 to 14 A	1
Output Voltage Variation		1.1	1.5	V	Vin = 270 V; Iout = 0 to 14 A	2
Output Voltage Variation		0.4	0.8	V	Vin = 270 V; Iout = 0 to 14 A	3
Total Output Voltage Range	21.5		48.5	V	Over line, load, temperature, & life	
Output Voltage Ripple and Noise (pk-pk)		440		mV	Bandwidth = 20 MHz; Cload=0 µF	See Note 5
Operating Output Current Range	0		14	A	Vin = 270 V	1, 2, 3
Operating Output Power Range	0		400	W	Vin = 230 V to 400 V	1, 2, 3
Output DC Current-Limit Inception	18.0	20.2	22.2	A	See Note 4; Vin = 270 V	1, 2, 3
Maximum Output Capacitance			1,000	µF	Iout ≤ half load resistive	See Note 5
EFFICIENCY						
Iout = 14 A (270 Vin)	92	95		%		1, 2, 3
Iout = 7 A (270 Vin)	92	95		%		1

MQBQ-270-28B ELECTRICAL CHARACTERISTICS (Continued)

Parameter	Min.	Typ.	Max.	Units	Notes & Conditions	Group A Subgroup
Specifications subject to change without notice						
					V _{in} =270 Vdc, P _{out} =400 W, T _{case} =25 °C, C _{load} =0 μF, free running (see Note 6) unless otherwise specified.	(see Note 18)
ISOLATION CHARACTERISTICS						
Isolation Voltage						
Input RTN to Output RTN	500			V	Dielectric strength	1
Input Pin to Case	500			V		1
Any Output Pin to Case	500			V		1
Isolation Resistance (in rtn to out rtn)	100			MΩ		1
Isolation Resistance (pin to case)	100			MΩ		1
Isolation Capacitance (in rtn to out rtn)		47		nF		1
FEATURE CHARACTERISTICS						
Input/output Ripple Frequency (free running)	500	550	600	kHz	Switching devices run at half this frequency	1, 2, 3
Synchronization Input						
Frequency Range	500		700	kHz		1, 2, 3
Logic Level High	2.0		3.3	V		See Note 5
Logic Level Low	0		0.8	V		See Note 5
Duty Cycle	20		80	%		See Note 5
Synchronization Output						
Pull Down Current	20			mA	VSYNC OUT = 0.8 V	See Note 5
Duty Cycle	40		60	%		See Note 5
Enable Control (ENA)						
Off-State Voltage			0.8	V		See Note 5
Module Off Pulldown Current	80			μA	Current drain required to ensure module is off	See Note 5
On-State Voltage	2			V		See Note 5
Module On Pin Leakage Current			20	μA	I _{max} draw from pin allowed with module still on	See Note 5
Pull-Up Voltage	3.2	4.5	4.8	V	See Figure A	1, 2, 3
RELIABILITY CHARACTERISTICS						
Calculated MTBF (MIL-STD-217F2)						
GB @ T _{case} = 70 °C		2000		10 ³ Hrs.		
AIF @ T _{case} = 70 °C		200		10 ³ Hrs.		
WEIGHT CHARACTERISTICS						
Device Weight		83		g		

Electrical Characteristics Notes

1. Converter will undergo input over-voltage shutdown.
2. Derate output power for continuous operation per Figure 5.
3. High or low state of input voltage must persist for about 200 μs to be acted on by the shutdown circuitry.
4. Current Limit inception is defined as the point where the output voltage has dropped to 90% of its nominal value.
Current limit inception is a function of input voltage. See Current Limit discussion in Features Description section.
5. Parameter not tested but guaranteed to the limit specified.
6. Operating the converter at a synchronization frequency above the free running frequency will cause the converter's efficiency to be slightly reduced and it may also cause a slight reduction in the maximum output current/power available. For more information consult the factory.
7. After a disable or fault event, module is inhibited from restarting for 100 ms. See Shut Down section of the Control Features description.
8. Only the ES and HB grade products are tested at three temperatures. The C grade products are tested at one temperature.
Please refer to the Construction and Environmental Stress Screening Options table for details.
9. These derating curves apply for the ES and HB grade products. The C grade product has a maximum case temperature of 70 °C.
10. The specified operating case temperature for ES grade products is -45 °C to 100 °C.
The specified operating case temperature for C grade products is 0 °C to 70 °C.



Technical Specification

MQBQ-270-28B
Output: 28V
Current: 14A

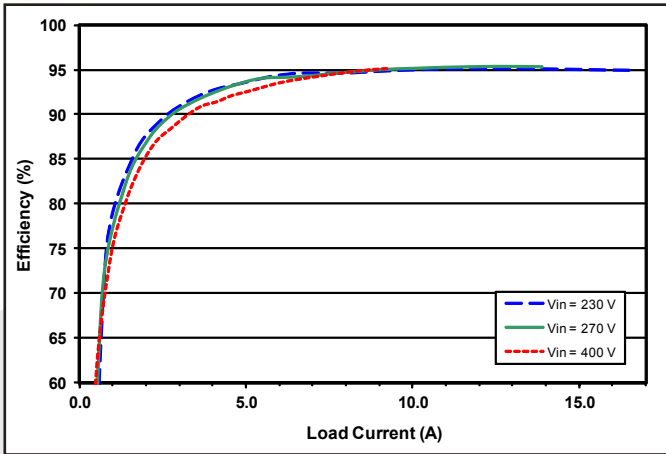

Figure 1: Efficiency vs. load current for minimum, nominal, and maximum input voltage at $T_{case}=25\text{ }^{\circ}\text{C}$.

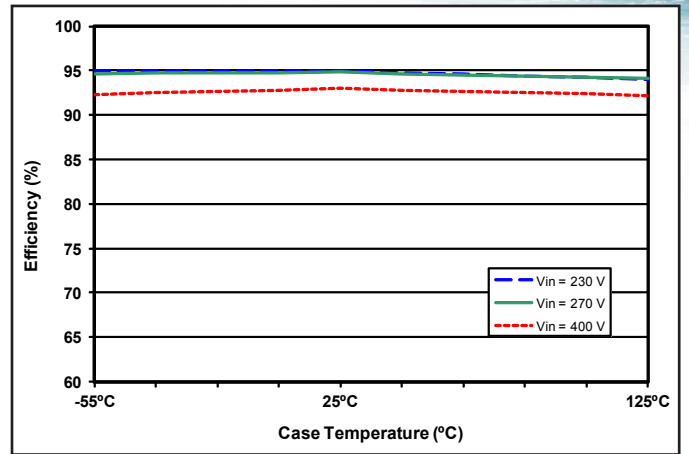

Figure 2: Efficiency vs. case temperature for minimum, nominal, and maximum input voltage and 60% rated power.

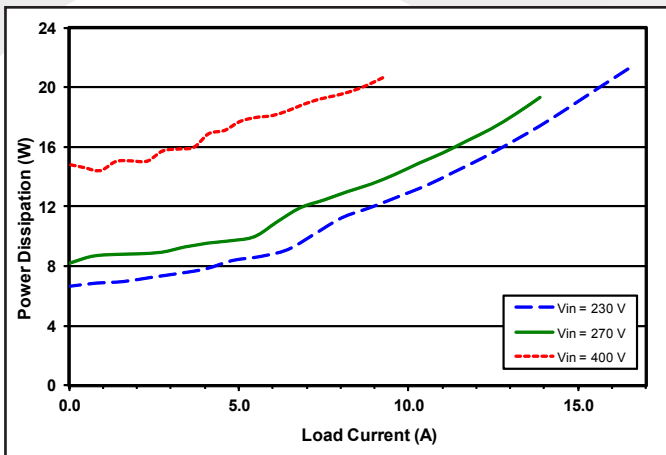

Figure 3: Power dissipation vs. load current for minimum, nominal, and maximum input voltage at $T_{case}=25\text{ }^{\circ}\text{C}$.

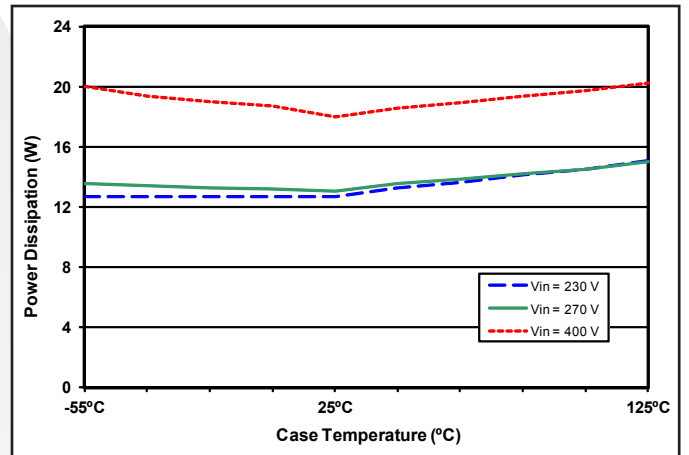

Figure 4: Power dissipation vs. case temperature for minimum, nominal, and maximum input voltage and 60% rated power.

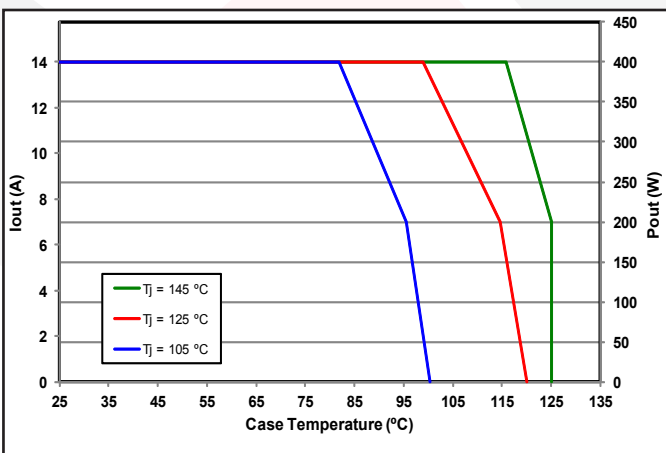

Figure 5: Output current and power derating curves vs. case temperature at nominal input voltage and at $T_j=105\text{ }^{\circ}\text{C}$, $125\text{ }^{\circ}\text{C}$, and $145\text{ }^{\circ}\text{C}$ (see Note 9).

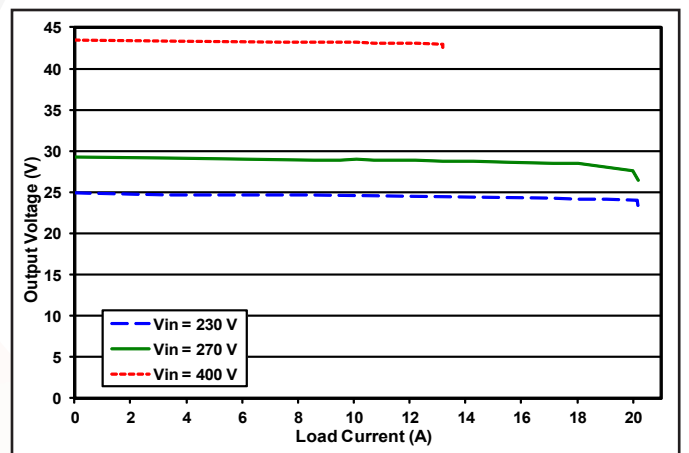

Figure 6: Output voltage vs. load current, current limit curves for minimum, nominal, and maximum input voltage at $T_{case}=25\text{ }^{\circ}\text{C}$.



Technical Specification

MQBQ-270-28B
Output: 28V
Current: 14A

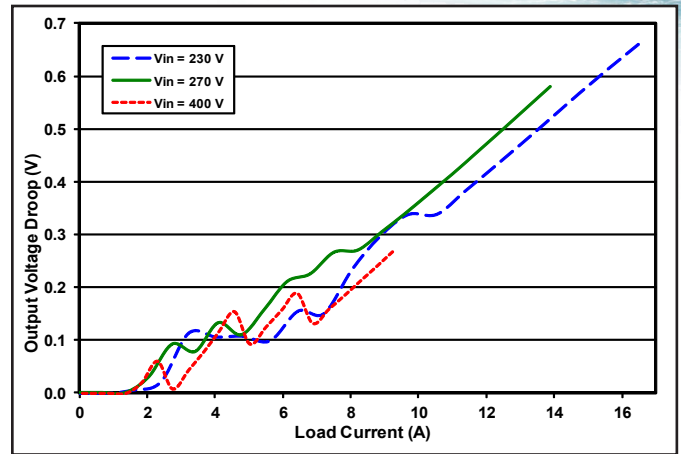
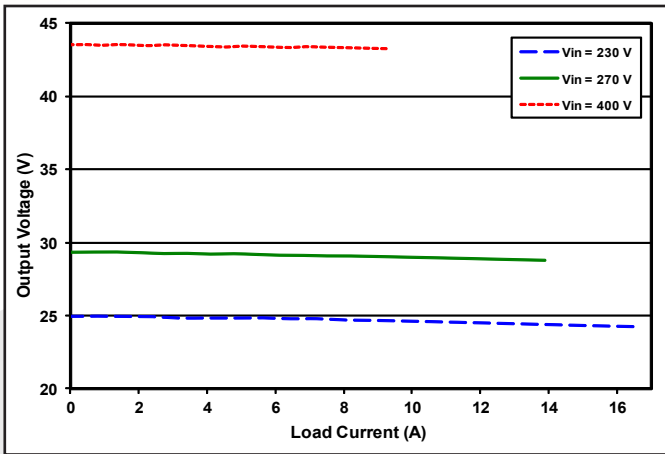

Figure 7 Output voltage vs. load current, regulation curves for minimum, nominal, and maximum input voltage at $T_{case}=25\text{ }^{\circ}\text{C}$.

Figure 8: Output voltage droop vs. load current for minimum, nominal, and maximum input voltage at $T_{case}=25\text{ }^{\circ}\text{C}$.

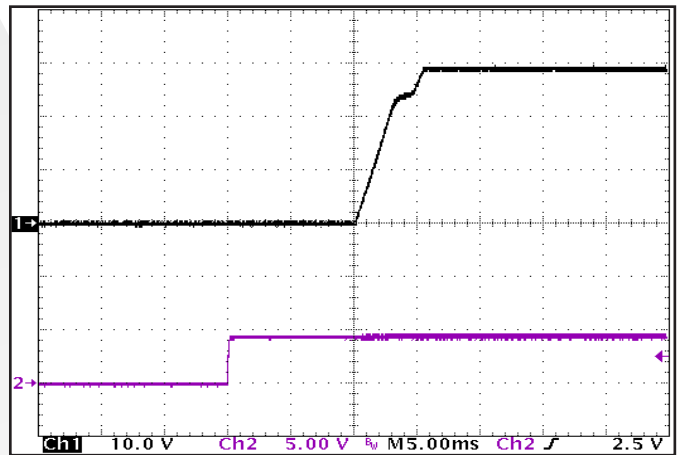
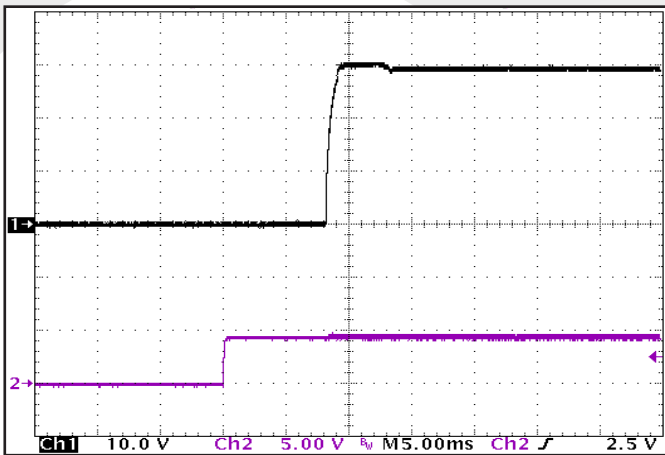

Figure 9: Turn-on transient at no load and 11 μF output capacitance initiated by ENA. Input voltage pre-applied. Ch 1: V_{out} (10 V/div). Ch 2: ENA (5 V/div).

Figure 10: Turn-on transient at half resistive load and 500 μF output capacitance initiated by ENA. Input voltage pre-applied. Ch 1: V_{out} (10 V/div). Ch 2: ENA (5 V/div).

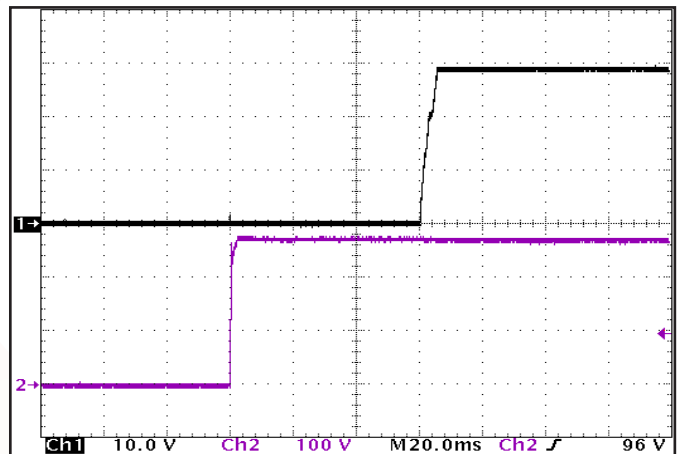
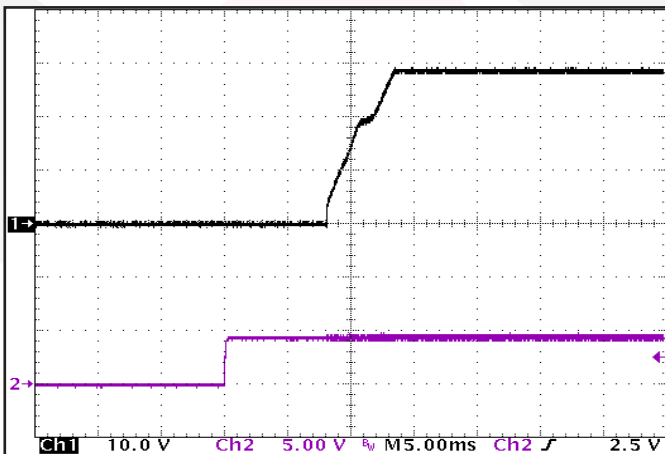

Figure 11: Turn-on transient at full resistive load and 11 μF output capacitance initiated by ENA. Input voltage pre-applied. Ch 1: V_{out} (10 V/div). Ch 2: ENA (5 V/div).

Figure 12: Turn-on transient at full resistive load and 11 μF output capacitance initiated by V_{in} . ENA previously high. Ch 1: V_{out} (10 V/div). Ch 2: V_{in} (100 V/div).

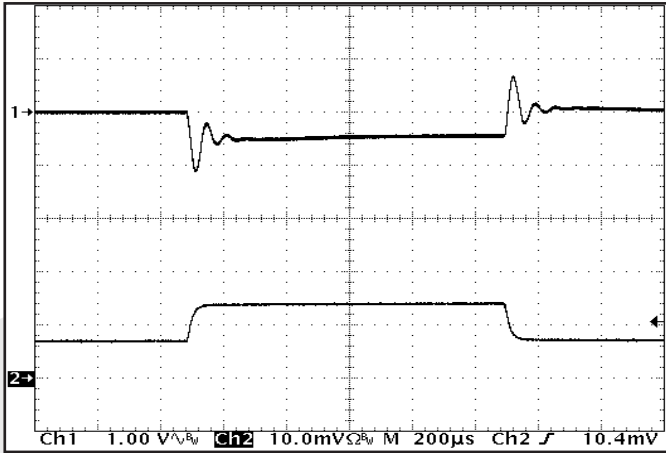

Figure 13: Output voltage response to step-change in load current 50%-100%-50% of I_{out} (max). Load capacitance: 1 μ F ceramic and 10 μ F 100 m Ω ESR tantalum. Ch 1: V_{out} (1 V/div). Ch 2: I_{out} (10 A/div).

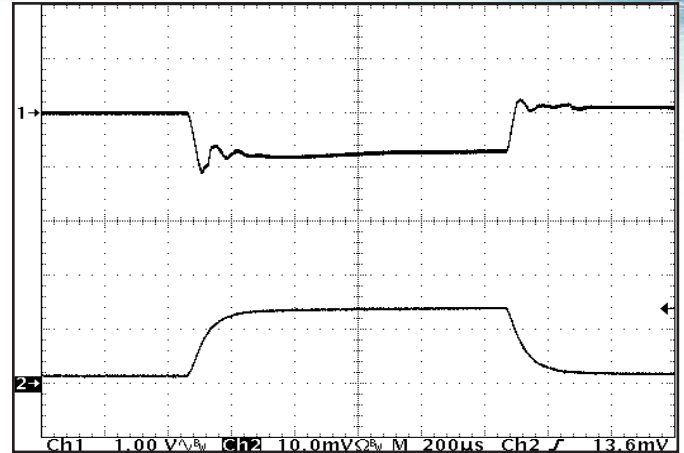

Figure 14: Output voltage response to step-change in load current 10%-100%-10% of I_{out} (max). Load capacitance: 1 μ F ceramic and 10 μ F 100 m Ω ESR tantalum. Ch 1: V_{out} (1 V/div). Ch 2: I_{out} (10 A/div).

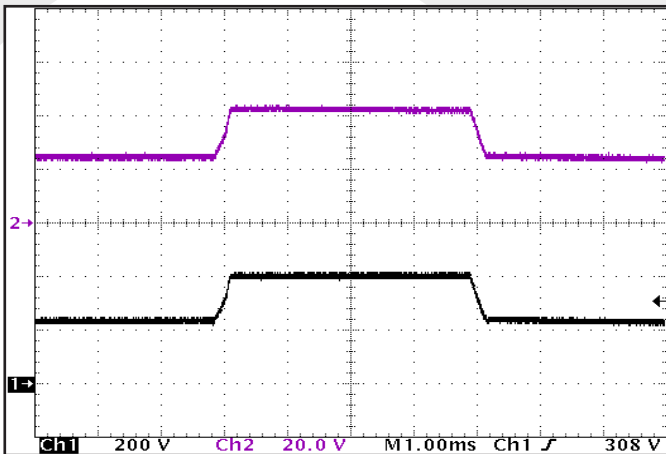

Figure 15: Output voltage response to step-change in input voltage 230 V-400 V-230 V in 250 μ s. Load capacitance: 1 μ F ceramic and 10 μ F 100 m Ω ESR tantalum. Ch 1: V_{in} (200 V/div). Ch 2: V_{out} (20 V/div).

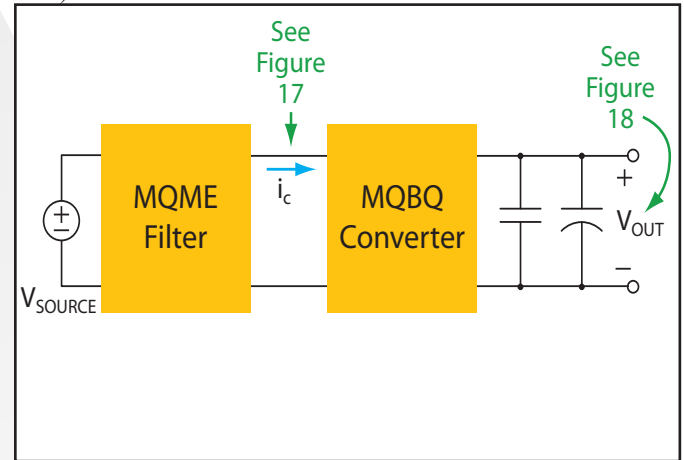

Figure 16: Test set-up diagram showing measurement points for input terminal current ripple (Figure 17) and output voltage ripple (Figure 18).

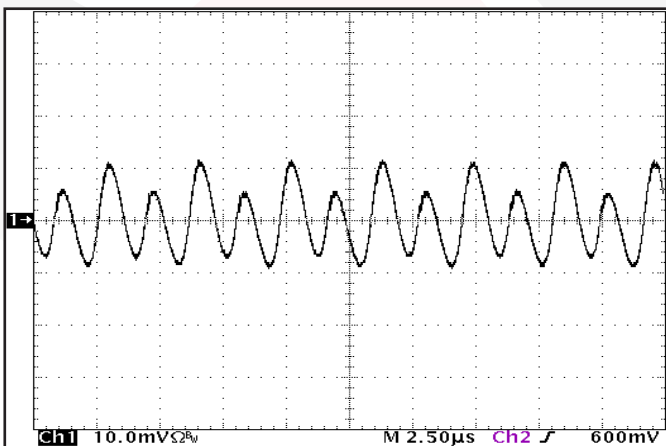

Figure 17: Input terminal current ripple, i_c at full load and nominal input voltage with SynQor MQ filter module (50 mA/div). Bandwidth: 20 MHz. See Figure 16.

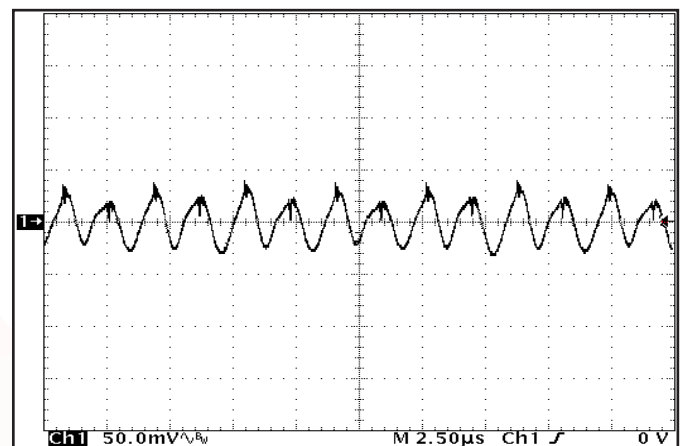

Figure 18: Output voltage ripple, V_{out} , at nominal input voltage and full load (50 mV/div). Bandwidth: 20 MHz. Load capacitance: 1 μ F ceramic and 10 μ F 100 m Ω ESR tantalum. See Figure 16.



Technical Specification

MQBQ-270-28B
Output: 28V
Current: 14A

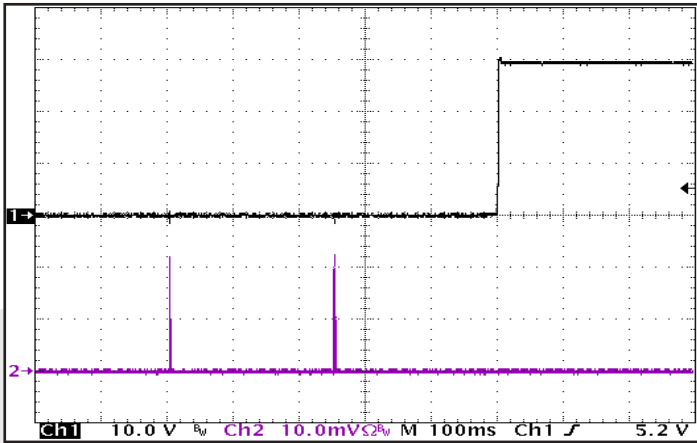

Figure 19: Rise of output voltage after the removal of a short circuit across the output terminals. $R_{short} = 5\text{ m}\Omega$. Ch 1: V_{out} (10 V/div). Ch 2: I_{out} (20 A/div). Bandwidth: 20 MHz.



MQBQ-270-28B
Output: 28V
Current: 14A

Technical Specification

BASIC OPERATION AND FEATURES

The MQBQ Bus Converters use full bridge power conversion stage to implement a DC transformer. The output voltage is proportional to the input voltage by the transformer turns ratio. During steady state operation, the primary and secondary switching devices operate with effectively 50 % duty cycle (there is not PWM action). The full bridge stage switches at a fixed frequency for predictable EMI performance. Due to the push-pull nature of this stage it creates a ripple at double its switching frequency. As a result, both the input and the output of the converter have a fundamental ripple frequency of about 550 kHz in the free-running mode.

Rectification of the isolation stage's output is accomplished with synchronous rectifiers. These devices, which are MOSFETs with a very low resistance, dissipate far less energy than would Schottky diodes. This is the primary reason why the MQBQ converter have such high efficiency.

Besides improving efficiency, the synchronous rectifiers permit operation down to zero load current. There is no longer a need for a minimum load, as is typical for converters that use diodes for rectification. The synchronous rectifiers actually permit a negative load current to flow back into the converter's output terminals if the load is a source of short or long term energy. The MQBQ converters do not limit the negative current that can flow from the load back to the source. Operation in this mode for a prolonged time is not recommended.

There is a control circuit on both the input and output sides of the MQBQ converter that determines the conduction state of the power switches. These circuits communicate with each other across the isolation barrier through a magnetically coupled device. No opto-isolators are used.

A separate bias supply provides power to both the input and output control circuits. Among other things, this bias supply permits the converter to operate indefinitely into a short circuit (hic-cup type operation).

An input under-voltage lockout feature with hysteresis is provided, as well as an input over-voltage shutdown. There is also an output current limit that is nearly constant as the load impedance decreases to a short circuit. The MQBQ is allowed to run in current limit mode for a short time before shutting down. When a load fault is removed and the fault inhibit time has elapsed, the converter will go through its normal soft start sequence.

The MQBQ converter's control circuit does not implement an over-temperature shutdown.

The following sections describe the use and operation of additional control features provided by the MQBQ converter.

CONTROL FEATURES

ENABLE: The MQBQ converter has one enable pin. The enable pin must have a logic high level for the converter to be enabled. A logic low will inhibit the converter.

The ENA pin (pin 4) is referenced with respect to the converter's input return (pin 2).

The enable pin can be used to turn the main power stage on and off, but the bias supply is not controlled by the enable pin. If the input voltage is above input under voltage lockout, the bias supply will turn on and remain on until the input voltage drops below this voltage.

The enable pin is internally pulled high so that an open connection on the pin will enable the converter. Figure A shows the equivalent circuit looking into the enable pin (primary referenced). It is TTL compatible.

SHUT DOWN: The MQBQ converter will shut down in response to only four conditions: ENA input low, VIN input below under-voltage lockout threshold, VIN input above over-voltage shutdown threshold, or a prolonged over current / short circuit condition. Following a shutdown event, there is a startup inhibit delay which will prevent the converter from restarting for approximately 250 ms. After the 250 ms delay elapses, if the enable input is high and the input voltage is within the operating range, the converter will restart. If the VIN input is brought down to nearly 0V and back into the operating range, there is no startup inhibit, and the output voltage will rise according to the "Turn-On Delay, Rising Vin" specification.

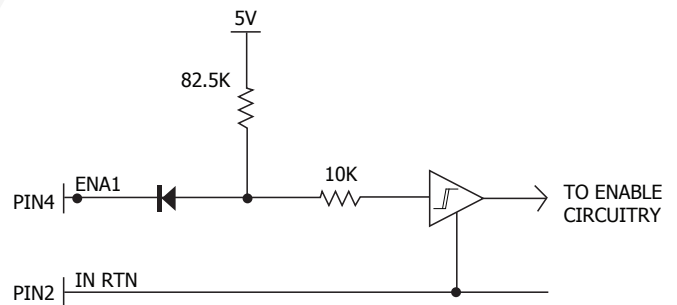

Figure A: Circuit diagram shown for reference only, actual circuit components may differ from values shown for equivalent circuit.



MQBQ-270-28B
Output: 28V
Current: 14A

Technical Specification

SYNCHRONIZATION: The MQBQ converter's switching frequency can be synchronized to an external frequency source that is in the 500 kHz to 700 kHz range. A pulse train at the desired frequency should be applied to the SYNC IN pin (pin 6) with respect to the INPUT RETURN (pin 2). This pulse train should have a duty cycle in the 20% to 80% range. Its low value should be below 0.8 V to be guaranteed to be interpreted as a logic low, and its high value should be above 2.0 V to be guaranteed to be interpreted as a logic high. The transition time between the two states should be less than 300 ns.

If the MQBQ converter is not to be synchronized, the SYNC IN pin should be left open circuit. The converter will then operate in its free-running mode at a frequency of approximately 550 kHz.

If, due to a fault, the SYNC IN pin is held in either a logic low or logic high state continuously, the MQBQ converter will revert to its free-running frequency. The MQBQ converter also has two SYNC OUT pins (pin 5 and pin 12). The SYNC OUT 1 signal (primary referenced) can be used to drive the SYNC IN pins of as many as ten (10) other MQBQ converters. The pulse train coming out of SYNC OUT 1 has a duty cycle of 50% and a frequency that matches the switching frequency of the converter with which it is associated. This frequency is either the free-running frequency if there is no synchronization signal at the SYNC IN pin, or the synchronization frequency if there is. SYNC OUT is also available referenced to the secondary side on pin 12 (referenced to output return; pins 7, 8, or 9). The SYNC OUT 2 signal can be used to synchronize down stream converters connected to the output bus.

The SYNC OUT signal is available only when the DC input voltage is above the input under voltage lockout and when the converter is not inhibited through the ENA pin.

NOTE: An MQBQ converter that has its SYNC IN pin (primary referenced) driven by the SYNC OUT pin (primary referenced) of a second MQBQ converter will have its start of its switching cycle delayed approximately 180 degrees relative to that of the second converter. Figure B shows the equivalent circuit looking into the SYNC IN pin / SYNC OUT 1 pin referenced to the primary. Figure C shows the equivalent circuit looking into the SYNC OUT 2 pin (secondary side reference).

CURRENT SHARE: Like most Bus Converters, several MQBQ's can be placed in parallel to achieve either a higher total load power or N+1 redundancy. As long as the MQBQ's share, both, the same input source and output load, the total load will evenly split between MQBQ's as a result of its natural voltage droop characteristic.

INPUT UNDER-VOLTAGE LOCKOUT: The MQBQ converter has an under-voltage lockout feature that ensures the converter will be off if the input voltage is too low. The threshold of input voltage at which the converter will turn on is higher than the threshold at which it will turn off. In addition, the MQBQ converter will not respond to a state of the input voltage unless it has remained in that state for more than about 200 μ s. This hysteresis and the delay ensure proper operation when the source impedance is high or in a noisy environment.

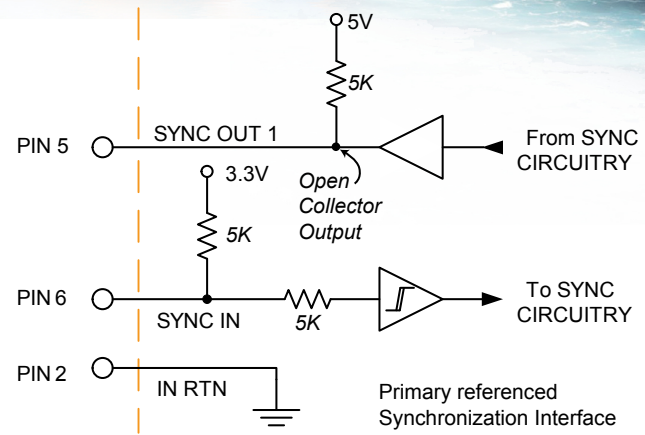

Figure B: SYNC IN / SYNC OUT (1) equivalent circuits referenced to the input return pin (IN RTN).

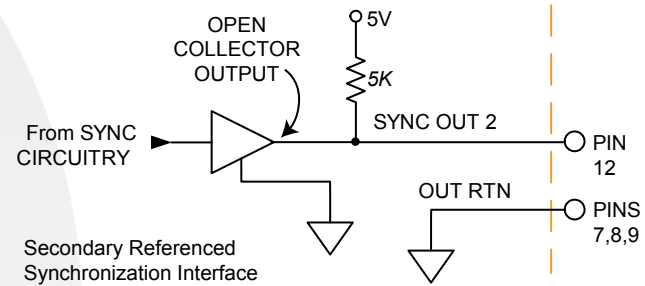

Figure C: Equivalent circuit looking into SYNC OUT 2 pin with respect to the OUT RTN (output return) pin.

INPUT OVER-VOLTAGE SHUTDOWN: The MQBQ converter also has a two stage over-voltage feature that limits the converter's duty cycle for 100 ms before shutdown and a higher second level with no delay before shutdown if the input voltage is too high (See the Input Over-Voltage Shutdown section in the Electrical Characteristics Table for specific voltage levels). It also has a hysteresis and time delay to ensure proper operation.

THERMAL CONSIDERATIONS: Figure 5 shows the suggested Power Derating Curves for this converter as a function of the case temperature and the maximum desired power MOSFET junction temperature. All other components within the converter are cooler than its hottest component, which at full power is no more than 20 °C higher than the case temperature directly below this component.

The Mil-HDBK-1547A component derating guideline calls for a maximum component temperature of 105 °C. Figure 5 therefore has one power derating curve that ensures this limit is maintained. It has been SynQor's extensive experience that reliable long-term converter operation can be achieved with a maximum component temperature of 125 °C. In extreme cases, a maximum temperature of 145 °C is permissible, but not recommended for long-term operation where high reliability is required. Derating curves for these higher temperature limits are also included in Figure 5.



MQBQ-270-28B
Output: 28V
Current: 14A

Technical Specification

When the converter is mounted on a metal plate, the plate will help to make the converter's case bottom a uniform temperature. How well it does so depends on the thickness of the plate and on the thermal conductance of the interface layer (e.g. thermal grease, thermal pad, etc.) between the case and the plate. Unless this is done very well, it is important not to mistake the plate's temperature for the maximum case temperature. It is easy for them to be as much as 5-10 °C different at full power and at high temperatures. It is suggested that a thermocouple be attached directly to the converter's case through a small hole in the plate when investigating how hot the converter is getting. Care must also be made to ensure that there is not a large thermal resistance between the thermocouple and the case due to whatever adhesive might be used to hold the thermocouple in place.

REVERSE CURRENT OPERATION: Converters that use MOSFETs as synchronous rectifiers are capable of drawing a negative current from the load if the load is a source of short- or long-term energy. This negative current is referred to as a "back-drive current".

During steady state operation the MQBQ converters do not have any protection feature that would limit the back-drive current. Therefore, the MQBQ module will allow unlimited amount of current to flow from the output to the input source when the output is raised above the expected steady state voltage for any given input voltage. Prolonged operation of the MQBQ converter in this mode can result in permanent damage. The MQBQ converters do have the necessary circuitry to start-up and shut down into a back-drive condition (preexisting voltage at the output pins), as long as the voltage at the output does not exceed the expected steady state output voltage for any given input voltage.



MQBQ-270-28B
Output: 28V
Current: 14A

Technical Specification

CONSTRUCTION AND ENVIRONMENTAL STRESS SCREENING OPTIONS

Screening	Consistent with MIL-STD-883F	C-Grade (specified from 0 °C to +70 °C)	ES-Grade (specified from -45 °C to +100 °C)	HB-Grade (specified from -55 °C to +125 °C)
Element Evaluation		No	Yes	Yes
Internal Visual	IPC-A-610 Class 3	Yes	Yes	Yes
Temperature Cycle	Method 1010	No	Condition B (-55 °C to +125 °C)	Condition C (-65 °C to +150 °C)
Constant Acceleration	Method 2001 (Y1 Direction)	No	500 g	Condition A (5000 g)
Burn-in	Method 1015	24 Hrs @ +125 °C	96 Hrs @ +125 °C	160 Hrs @ +125 °C
Final Electrical Test	Method 5005 (Group A)	+25 °C	-45, +25, +100 °C	-55, +25, +125 °C
Mechanical Seal, Thermal, and Coating Process			Full QorSeal	Full QorSeal
External Visual	Method 2009	Yes	Yes	Yes
Construction Process			QorSeal	QorSeal

MilQor® Hi-Rel converters and filters are offered in three variations of environmental stress screening options. All ES-Grade and HB-Grade MilQor Hi-Rel converters use SynQor’s proprietary QorSeal® Hi-Rel assembly process that includes a Parylene-C coating of the circuit, a high performance thermal compound filler, and a nickel barrier gold plated aluminum case. Each successively higher grade has more stringent mechanical and electrical testing, as well as a longer burn-in cycle. The ES- and HB-Grades are also constructed of components that have been procured through an element evaluation process that pre-qualifies each new batch of devices.



MQBQ-270-28B
Output: 28V
Current: 14A

Technical Specification

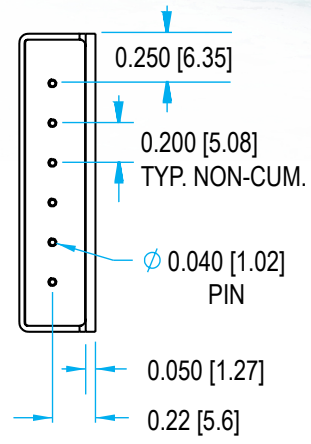
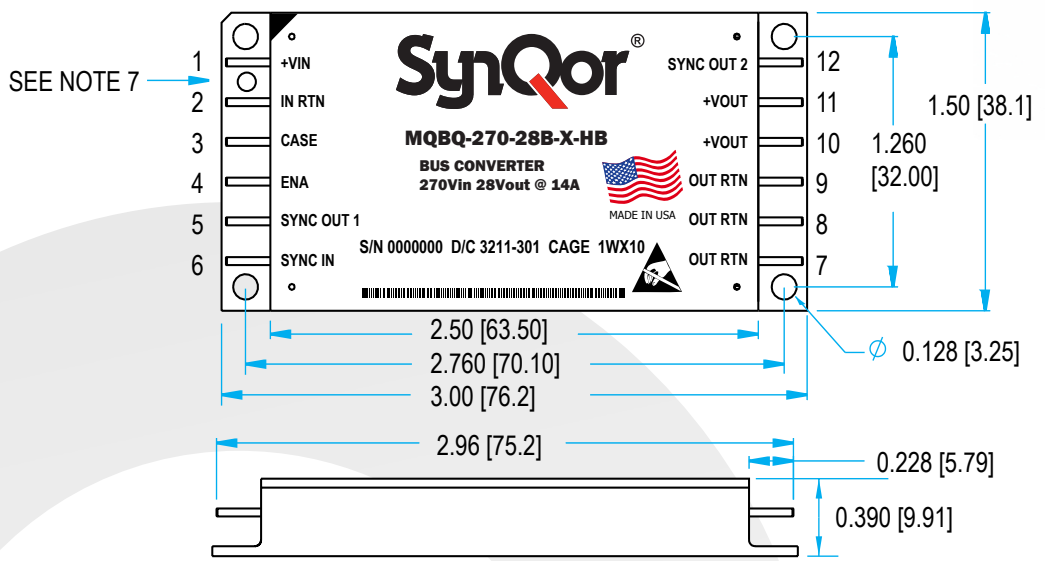

Case X

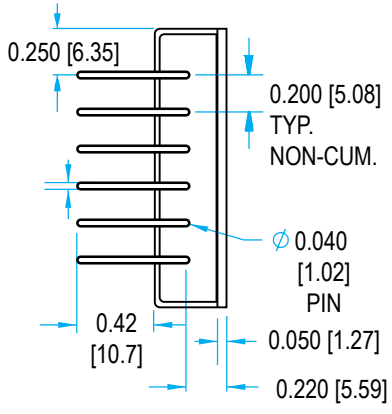
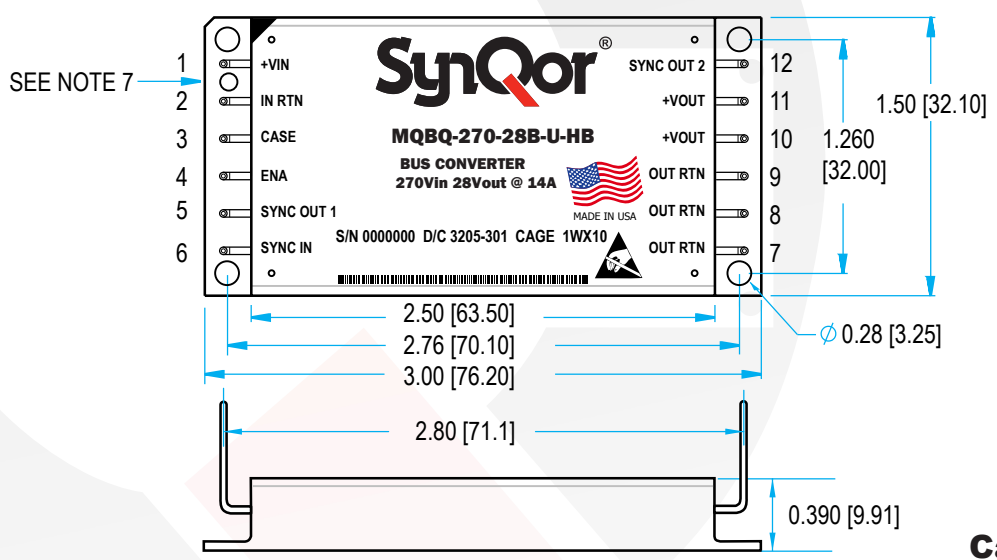

Case U

NOTES

- 1) Pins 0.040" (1.02mm) diameter
- 2) Pins Material: Copper
Finish: Gold over Nickel plate
- 3) All dimensions in inches (mm) Tolerances: x.xx +/-0.02 in. (x.x +/-0.5mm)
x.xxx +/-0.010 in. (x.xx +/-0.25mm)
- 4) Weight: 2.9 oz (83 g) typical
- 5) Workmanship: Meets or exceeds IPC-A-610C Class III
- 6) Print Labeling on Top Surface per Product Label Format Drawing
- 7) Pin 1 identification hole, not intended for mounting

PIN DESIGNATIONS

Pin #	Function	Pin #	Function
1	+ VIN	7	OUT RTN
2	IN RTN	8	OUT RTN
3	CASE	9	OUT RTN
4	ENA	10	+ VOUT
5	SYNC OUT 1	11	+ VOUT
6	SYNC IN	12	SYNC OUT 2*

* Secondary Referenced



MQBQ-270-28B
Output: 28V
Current: 14A

Technical Specification

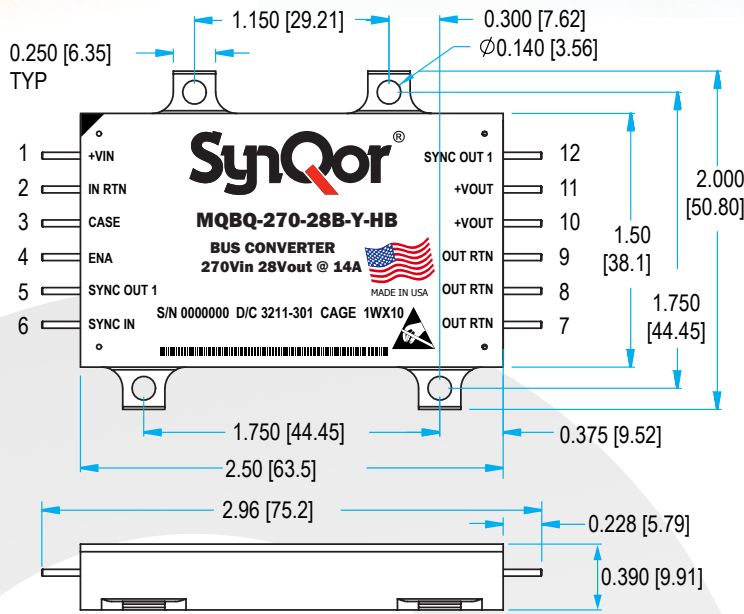

Case Y

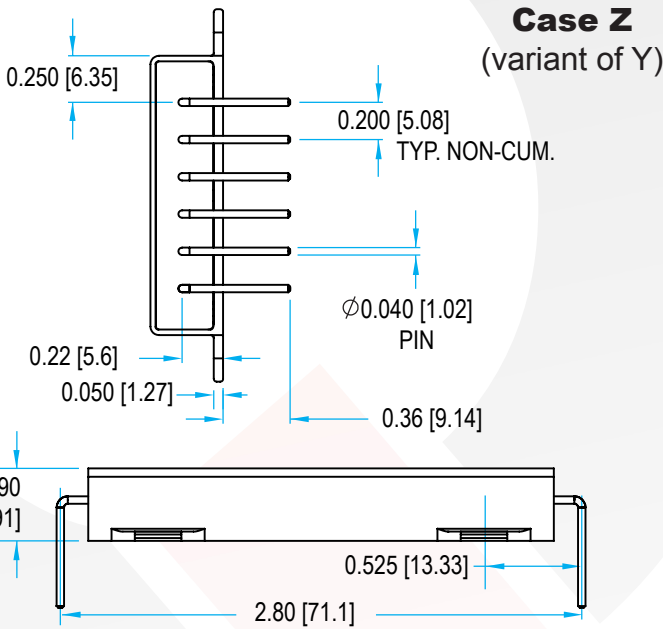

Case Z
(variant of Y)

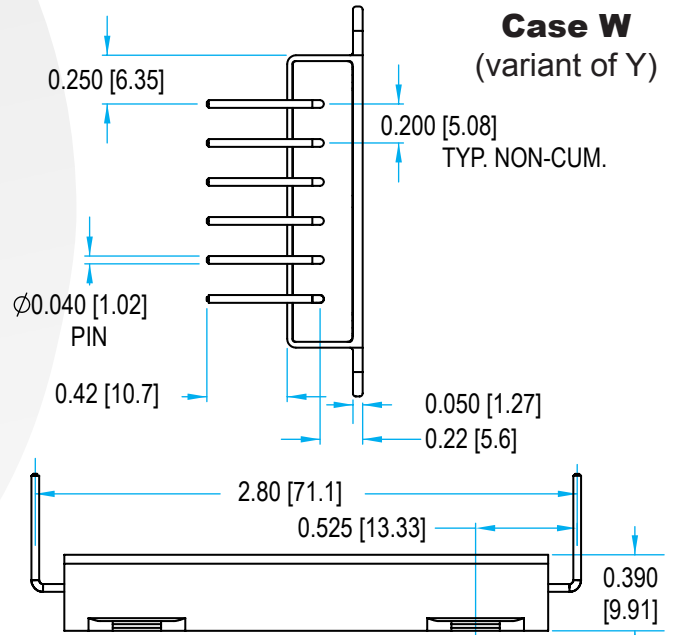

Case W
(variant of Y)

NOTES

- 1) Pins 0.040" (1.02mm) diameter
- 2) Pins Material: Copper
Finish: Gold over Nickel plate
- 3) All dimensions in inches (mm) Tolerances: x.xx +/-0.02 in. (x.x +/-0.5mm)
x.xxx +/-0.010 in. (x.xx +/-0.25mm)
- 4) Weight: 2.9 oz (83 g) typical
- 5) Workmanship: Meets or exceeds IPC-A-610C Class III
- 6) Print Labeling on Top Surface per Product Label Format Drawing
- 7) Pin 1 identification hole, not intended for mounting

PIN DESIGNATIONS

Pin #	Function	Pin #	Function
1	+ VIN	7	OUT RTN
2	IN RTN	8	OUT RTN
3	CASE	9	OUT RTN
4	ENA	10	+ VOUT
5	SYNC OUT 1	11	+ VOUT
6	SYNC IN	12	SYNC OUT 2*

* Secondary Referenced



Technical Specification

MQBQ-270-28B
Output: 28V
Current: 14A

PART NUMBERING SYSTEM

The part numbering system for SynQor's *MilQor* DC-DC converters follows the format shown in the table below.

Model Name	Nominal Input Voltage Range	Output Voltage(s)	Package Outline/ Pin Configuration	Screening Grade
		Nominal Output Voltage		
MQBQ	28 270	28B	U X Y W Z	C ES HB

Not all combinations make valid part numbers, please contact SynQor for availability. See the Product Summary web page for more options.

Example: MQBQ-270-28B-Y-ES

APPLICATION NOTES

A variety of application notes and technical white papers can be downloaded in pdf format from the SynQor website.

PATENTS

SynQor holds numerous U.S. patents, one or more of which apply to most of its power conversion products. Any that apply to the product(s) listed in this document are identified by markings on the product(s) or on internal components of the product(s) in accordance with U.S. patent laws. SynQor's patents include the following:

7,050,309 7,765,687 7,787,261
 8,149,597 8,644,027

Contact SynQor for further information and to order:

Phone: 978-849-0600
Toll Free: 888-567-9596
Fax: 978-849-0602
E-mail: mqnbofae@synqor.com
Web: www.synqor.com
Address: 155 Swanson Road
 Boxborough, MA 01719
 USA

Warranty

SynQor offers a two (2) year limited warranty. Complete warranty information is listed on our website or is available upon request from SynQor.